

# Observations on Concave Perspective

Stephen M Campbell

Unit 1a, Richmond Road, Trafford Park, UK; stephen@smcampbell.eu

## Abstract

This paper covers some brief discussions about perspective from the point of view of an artist and investigates how objects may appear if they were seen not from one point, but from a concave observation plane.

## Introduction

I was admiring fish at an aquarium when I observed that they appeared to diminish in size the closer they came to the glass. As I peered closer to observe how this came about, I walloped my head on the dome of glass which jutted out into the room. This paper investigates this alteration of perspective and how it may affect perception of the visual world.

### Classical Perspective

Alberti describes a method [1] of drawing the world by tracing outlines on an ‘intersection’ or transparent veil between the artist and the subject Figure 1a. This effect is then recreated by drawing lines from a vanishing point, which lies on the horizon at eye level with the artist. In reconstructing this effect onto a cartesian graph Figure 1b with an imaginary world of cubes, we can give each vertex co-ordinates in  $x y z$  space, measured by their distance from  $O$  the point of observation, and use the tangent of the angle subtended at  $O$  to plot the positions of the vertices on the  $x y$  graph as  $x'y'$ :

$$x' = \frac{x}{z} \quad y' = \frac{y}{z}$$

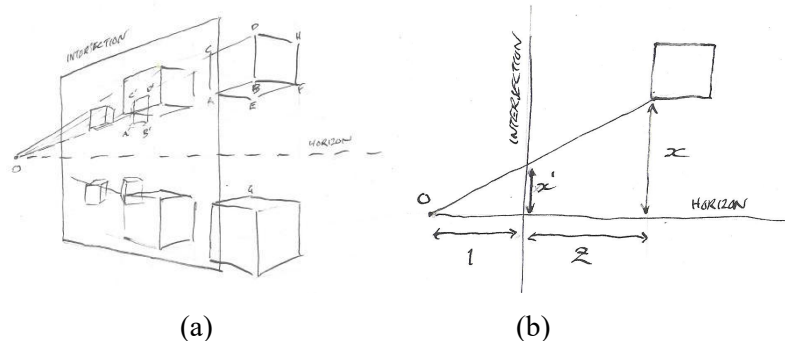

**Figure 1:** Alberti's Classical Perspective. (a) Objects in space are traced onto the ‘intersection.’ (b) The  $x$  co-ordinate is found by using the tangent of the angle at  $O$ .

Classical perspective can be distinguished from the following examples of perspective by the rule: “All straight lines remain straight in their perspective appearance.”[4]

### Cylindrical Perspective

William Herdman contradicted Classical perspective with his rule:

“A parallel line is a line parallel to any line passing the eye, and is convex in appearance. Its convexity increases with its distance from its parallel passing the eye, till an arc is formed, which is the limit of vision.”[3]

Herdman concentrates on the curvature of horizontal lines as vision reaches beyond the constraints of Alberti's intersection. In Alberti's terms, this would mean a cylindrical intersection Figure 2a. We can describe this perspective in a cartesian graph by calculating the tangent of the angle at O again to use as our y' co-ordinates and the angle subtended at the point of observation between the y axis and the vertex, to give us our x' co-ordinates.

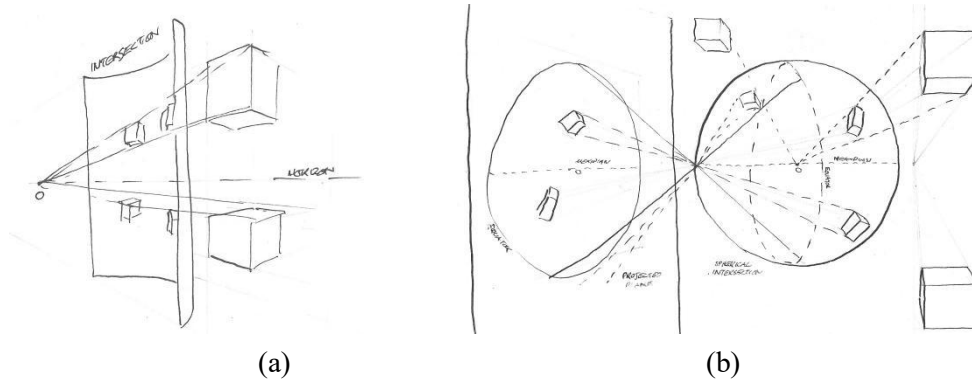

**Figure 2:** *Curvilinear perspective, objects in space are traced onto a curved intersection to be flattened or projected onto a plane: (a) cylindrical, (b) spherical*

### **Spherical Perspective**

Albert Flocon and Andre Barre use and adapt the stereographic projection in their work on Curvilinear Perspective. This approach to perspective looks at the complete world surrounding us by measuring the angles subtended at the point of observation along the x and y axes. Flocon and Barre distinguish their approach from the previous two by the rule: "The visual field of 180 is represented by a circular picture." [2] A simple demonstration of this is found by looking at a convex mirror, or lens with a visual angle greater than that of our foveal vision. In Alberti's terms, this would mean drawing on the inside of a spherical intersection which can then be stereographically projected. Figure 2b

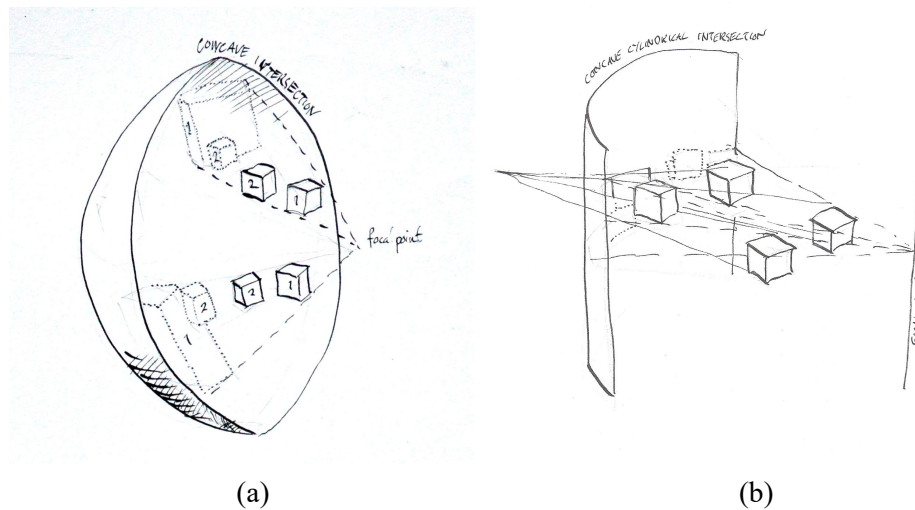

**Figure 3:** *Concave perspective, objects in space are within the curved intersection. (a) Spherical (b) Cylindrical.*

### **Concave Perspective**

The above mentioned perspectives have in common the fact that the world is observed from a single point (O). As objects move closer to O they appear larger, as the angle subtended at O increases. In a concave perspective, instead of angles being subtended at O, they are subtended from a focal point at the centre of

the sphere described by the spherical intersection onto which the object is projected Figure 3. This perspective occurs when looking at objects between a magnifying glass and its focal point or between a concave mirror and its focal point.

As creatures with binocular vision, we experience this effect when viewing close up objects. Though we experience the visual world in cohesive stereoscopic vision made into singular shapes and outlines, we could take a few liberties and observe this stereoscopic vision as perspective in reverse. If we hold one finger in front of us and another one closer, the closer finger doesn't obscure the further one, so in effect the closer finger is diminishing in width as it becomes closer (provided we have both eyes open). This may not be a perfect description, but would explain the difficulties to be had in drawing a still life.

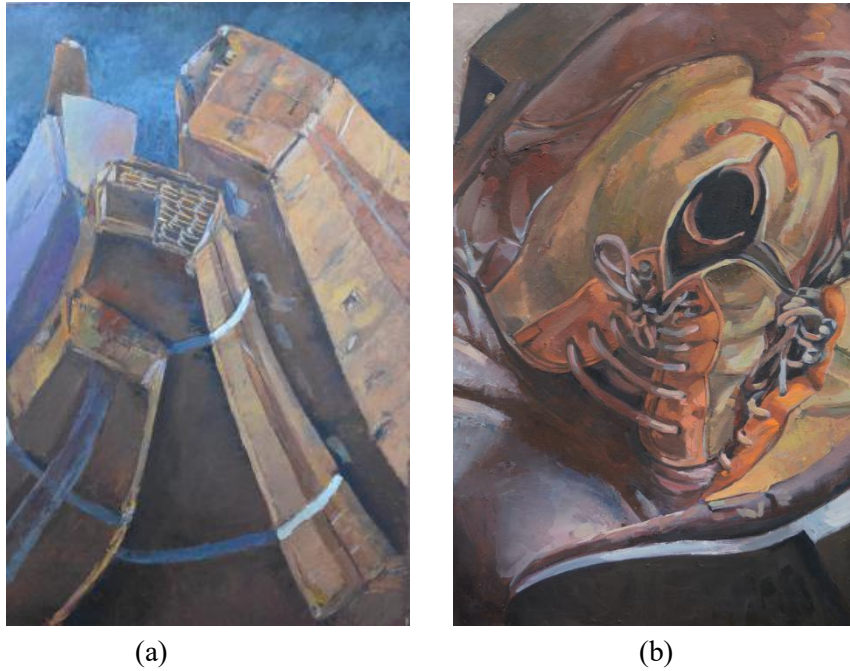

**Figure 4:** *Two examples of my take on concave spherical perspective, (a) boxes (b) shoes*

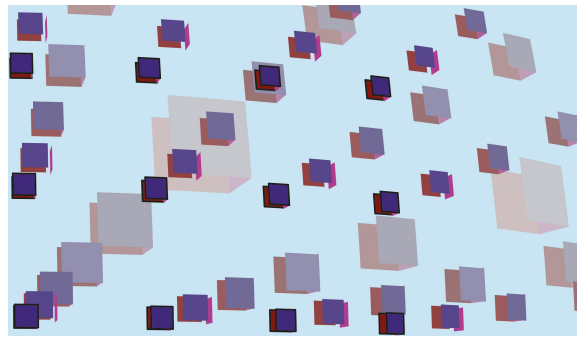

**Figure 5:** *A simple projection of concave spherical perspective*

The above image was made using a spreadsheet, I input a number of rows and columns of cubes and specified a radius between the spherical intersection and the focal point. Each vertex is given a co-ordinate in space  $x,y,z$ ; the radius of the spherical intersection is  $r$  and the following function is applied for the  $x$  and  $y$  axes:

$$r \sin \left( \cos^{-1} \left( \frac{\sqrt{y^2 + (r-z)^2}}{\sqrt{x^2 + y^2 + (r-z)^2}} \right) \right) = x'$$

The focal point  $f$  is at a distance  $r$  from the origin along the  $z$  axis. For a vertex  $a$ , being a point between the origin and  $f$ , we have its co-ordinates in  $x,y,z$  space. We want to know where a ray of length  $r$  coming from  $f$  and passing through  $a$  will hit the intersection which we can project onto our 2 dimensional cartesian graph to get  $x'$  and  $y'$ . In order to do this we need to know the angle subtended at  $f$  between the  $z$  axis and the axis we are looking for. We can calculate the distance to  $a$  from the focal point  $\sqrt{x^2 + y^2 + (r-z)^2} = hyp$ , where  $hyp$  is the distance from  $f$ . The distance along the  $y$  axis plane which

will form the side adjacent to our angle, is found similarly by  $\sqrt{y^2 + (r-z)^2} = adj$ . We can calculate the angle subtended on the  $x$  axis ( $\theta$ ) using trigonometry  $\cos \theta = \frac{adj}{hyp} = \frac{\sqrt{y^2 + (r-z)^2}}{\sqrt{x^2 + y^2 + (r-z)^2}}$ . Then in

order to project this angle onto the cartesian graph we use the angle subtended at  $f$  to create another triangle whose hypotenuse is  $r$  and opposite side is the distance along the  $x$  axis:  $r \sin \theta = x'$

This provides the angles subtended at  $f$  and the co-ordinates projected onto the intersection, allowing us to create a concave perspective rendering of the cubes. The cubes which are closer have been shaded darker than those that are further away. I have been quite simplistic in projecting the spherical intersection onto the cartesian plane, but at this point all manner of projecting spherical bodies onto two dimensions become available to us.

Further varieties of concave perspective have been explored by David Hockney and Aydın Büyüktaş in which the artists photograph the subject while panning around it in an arc. Instead of there being a focal point in this case, we have a straight focal line perpendicular to the curving axis, and a curving line of observation. This results in a combination of perspectives, where along one plane objects recede into the distance, while on the other they recede into the foreground.

## Conclusion

We don't have to go far to have our perception of the world changed. Much to the chagrin of authoritative art teachers, there are no universal laws of perspective.

I find this approach to painting amusing and a little subversive and I plan to use it to look at various subject matter that I believe it would be best used for.

## References

- [1] L. B. Alberti. *De Pictura*. 1435
- [2] A. Flocon and A. Barre. *Curvilinear Perspective*. Translated by R. Hansen University of California Press, 1968 p.119
- [3] W. Herdman. *A treatise on curvilinear perspective of Nature and its Applicability to Art* 1853 p. 64
- [4] G. A. Storey. *Theory and Practice of Perspective*. Clarendon Press, Oxford, 1910